

9. Lighting

9.1 Dynamo

Standard

The standard dynamo runs at the side of the tyre. To switch the light on and off the dynamo is switched so that it runs on the tyre or as the case may be, pulled away from the tyre to turn it off. Some dynamos have a button or lever, on many bicycles one must press the dynamo down to activate the switching mechanism.

The dynamo is removed from the tyre wall by pulling it away.

Important for quiet and easy running is the correct adjustment.

The dynamo should be adjusted so that the drive roller lies nicely on the tyre. If the tyre has a special running surface for the dynamo then adjustments should be made so that the driver roller runs on this surface. The dynamo's longitudinal axis seen from the middle of the driver roller should also lie along the radius of the wheel. To adjust this one is able to move the dynamo fastening device up and down the frame or fork.

Sometimes it is necessary to slightly bend the dynamo's fastening tab to provide an optimal result. This should always be seen as a final possibility and also be carried out with great care.

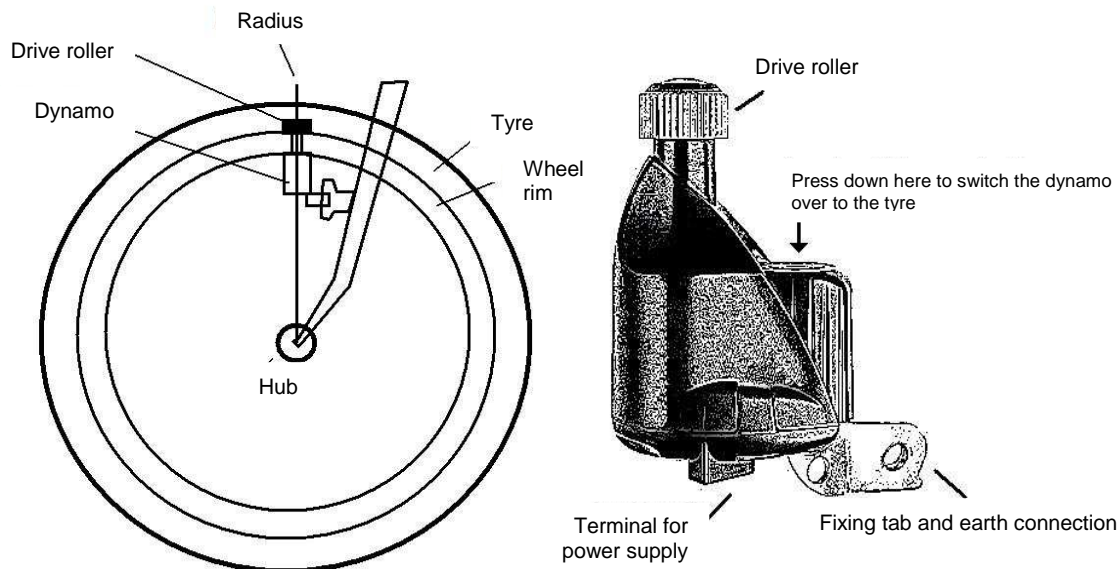

Once the dynamo has been adjusted correctly it can be tested to make sure that it works. To do this switch the dynamo on by switching it over to run on the tyre. Lift the wheel and revolve the wheel.

If one of the two lights does not function then check the terminal to this light and the terminal under the dynamo.

If both lights are without function then disconnect the wire from one of the lights and check again. If the other light functions then the fault lies with the light where you have disconnected the wire. Now swap the wires around, if the lights function then the wiring has been mixed up.

If the lights still don't function then connect the wires as originally connected and start again but disconnect the other light.

This fault can only occur with lighting systems with double wiring.

With single wiring the lights are earthed by means of the frame. If there is a fault here then please check the screws. Either they are too loose or the paint on the frame or fork is too thick; this can interrupt the current. In this case the paint is to be removed from the fixings to enable the current to flow.

If none of this is of any help then please contact the manufacturer or supplier.

Hub Dynamo

Mount the front wheel so that the hub dynamo terminal is on the right as seen when riding the bike.

The terminal must be aligned along the front fork or the rack support.

Installation is carried out as displayed in the image below; the terminal must be pointing upwards.

Do not try to turn the terminal by force after the axle nuts (torque 20Nm) have been tightened.

If it is forced it may be damaged or the wiring inside may break.

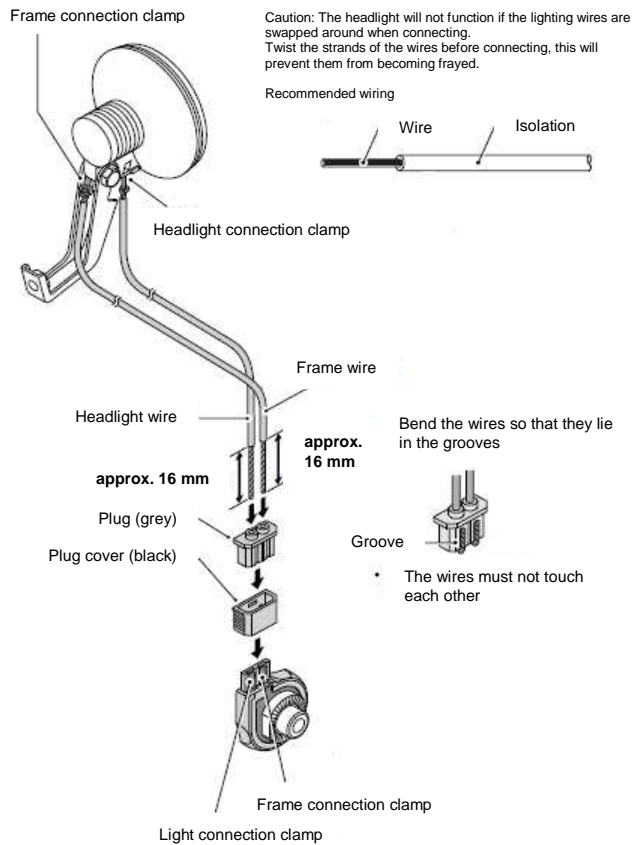

Fasten the wire to the front fork or rack support so that it does not get caught up in the spokes or other parts when riding.

If the position of the hub dynamo alters such as with a fork with springs, one must make sure that the cable is neither too tight nor too slack for the complete range of motion.

Connect so that the power from the hub dynamo passes along the light terminal wire to the frame terminal.

Remove the plug cover to disconnect the light from the dynamo.

Do not ride the bicycle with a disconnected plug cover because this will result in the wires getting caught up in the wheel.

Remove the plug cover before you take the wheel off.

If the wires are pulled strongly they may break resulting in poor contact.

When mounting the wheel it must be secured to the fork before fitting the plug cover.

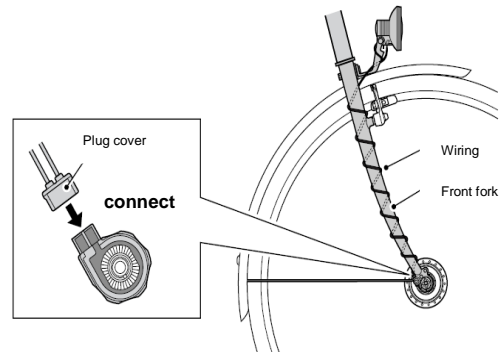

9.2 Rear Light

Standard

There are many different types of rear lights. However, the main difference is whether the light has one or two connections.

Rear lights with one wire are earthed by means of the mudguard or rack and power is supplied by the dynamo. With these lights one must first of all check the fixing screw (or screws). If the light does not shine then either it is too loose or the paint on the mudguard or rack is too thick; this can interrupt the current.

With a rear light with two wires it may be that the wires have been swapped around, this will cause a short-circuit and the lights will not shine.

For this reason swap the wires if the rear light is without function.

Battery

The battery powered rear light is independent of the dynamo, for this reason it has to be switched on separately. Before first use one may have to remove a tab, which separates the battery from the light to avoid that the light is switched on accidentally. Once the tab has been removed the circuit is closed and the light is able to be switched on and off.

The batteries in this type of light normally last for well over 100 hours.

9.3 Headlight

Standard

The standard headlight is mainly connected to the dynamo by means of a wire; the earthing by means of the headlight fixing device. If the headlight is without function one should check the wire and the fixing screws.

The same again here, if the fork paint is too thick or screws are too loose then the lighting may fail.

For Hub Dynamo

Headlights for hub dynamos normally have a switch to turn them on and off and two permanently attached wires. The functional principle is no different to that of the standard headlight.

If the light is without function then check the switch first. Turn it on and off a few times to make sure that it engages properly. If it is still without function then check the wiring.

First of all (if the bike is equipped with one) the wiring for the rear lighting has to be disconnected.

If the headlight remains without function then the fault lies either with the connection or the rear light itself.

If this is not the fault then check the hub dynamo and if necessary swap the plug wiring around.

Once the headlight functions the wiring for the rear light can be reconnected.